



# RCEL006-250

## Electric Actuators

# Technical Data

### Performance

Type	Max. torque (Nm)	Op. Time sek/90° 50HZ/60HZ	Max. stem dia.	Weight Kgs	No. of handle turns	Current draw max. (A) 24 VDC	Current draw max. (A) 1-ph 110V	Current draw max. (A) 1-ph 230V	Current draw max. (A) 3-ph 400V
RCEL006	58	17/14	22	11	8,5	2,3	0,65	0,38	0,15
RCEL009	88	17/14	22	11	8,5	3,5	1,0	0,56	0,17
RCEL015	147	20/17	22	14	10	4,5	1,2	0,70	0,27
RCEL019	186	20/17	22	14	10	4,5	1,2	0,70	0,27
RCEL028	274	24/20	32	17	12,5	7,0	2,0	0,70	0,3
RCEL038	373	24/20	32	18	12,5	-	2,0	1,06	0,37
RCEL050	490	24/20	32	19	12,5	-	3,1	1,18	0,5
RCEL060	588	29/24	42	22	14,5	-	3,1	1,18	0,5
RCEL080	785	29/24	42	23	14,5	-	4,5	1,8	0,8
RCEL100	981	29/24	42	25	14,5	-	4,5	2,0	0,87
RCEL150	1471	87/72	75	68	43,5	-	3,1	1,18	0,5
RCEL200	1962	87/72	75	70	43,5	-	4,5	1,8	0,8
RCEL250	2450	87/72	75	70	43,5	-	4,7	2,15	0,87

### Standard Specification

<b>Enclosure:</b>	Watertight IP67, Nema 4 and 6
<b>Ambient Temp:</b>	-30 °C to +70 °C, 150 °C/1 hr.
<b>Power Supply:</b>	24VDC 110VAC ±10%, 1-phase (50Hz/60Hz) 230VAC +5% -14%, 1-phase (50Hz/60Hz) 400VAC ±10%, 3-phase (50Hz/60Hz)
<b>Torque Switches:</b>	Open/Close (RCEL015 up to RCEL250)
<b>Limit Switches:</b>	Open/Close, 2+2 pcs
<b>Stall Protection:</b>	Built-in Thermal Protection Cut-off at 150 °C ± 5 °C/Reset at 97 °C ±15 °C
<b>Travel Angle:</b>	90° ± 5°
<b>Indicator:</b>	Continuous Position Indicator
<b>Manual Override:</b>	AUTO Declutching Mechanism
<b>Worm gear:</b>	Permanently lubricated and Selflocking
<b>Mechanical Stops:</b>	External Adjustable Limit Stops
<b>Space Heater:</b>	20W (24VDC, 110/230VAC) Anti-Condensation
<b>Conduit Entries:</b>	Two M20x1,5 (EExd BSP 3/4")
<b>Lubrication:</b>	Grease Moly (EP-Type)
<b>Materials:</b>	Steel, Aluminium Alloy, Al Bronze
<b>External Coating:</b>	Anodizing and Dry Powder Epoxy
<b>Duty Cycle S2:</b>	30 minutes, RCEL006-028 20 minutes, RCEL038 15 minutes, RCEL050-250
<b>Duty Cycle S4:</b>	50 %, RCEL006-028 30 %, RCEL038 25 %, RCEL050-250

### Optional Items

<b>EXP:</b>	EEx d IIB T4 IP67: RCEL006-RCEL100, ambient temp -20 °C to +55 °C
<b>DCM:</b>	Motor 24VAC (RCEL006-028)
<b>EXT:</b>	Travel Angle 120°, 135°, 180°, 270°, 300°
<b>LCU1:</b>	Local Control Unit Local/Remote Selector S/W Open/Stop/Close Selector S/W Aluminium Alloy
<b>LCU2:</b>	Local Control Unit Local/Remote Selector S/W Open/Stop/Close Selector S/W Plastic version
<b>PIU:</b>	Potentiometer Unit 1k Ohm
<b>CPT:</b>	Current Position Transmitter Output: 4-20mA DC
<b>PCU PB90:</b>	Proportional Control Unit Power Supply: 24VDC 110VAC, 1-phase (50Hz/60Hz) 400VAC, 3-phase (50Hz/60Hz) Input: 4-20mA DC, 0-10VDC Output: 4-20mA DC
<b>PCU DHC-100D:</b>	Proportional Control Unit Power Supply: 230VAC, 1-Phase Input: 4-20mA DC, 0-5VDC, 1-5VDC, 0-10VDC Output: 0-20mA DC, 0-10VDC Fail safe function
<b>IP68:</b>	Enclosure IP68

## RCEL006 - RCEL100

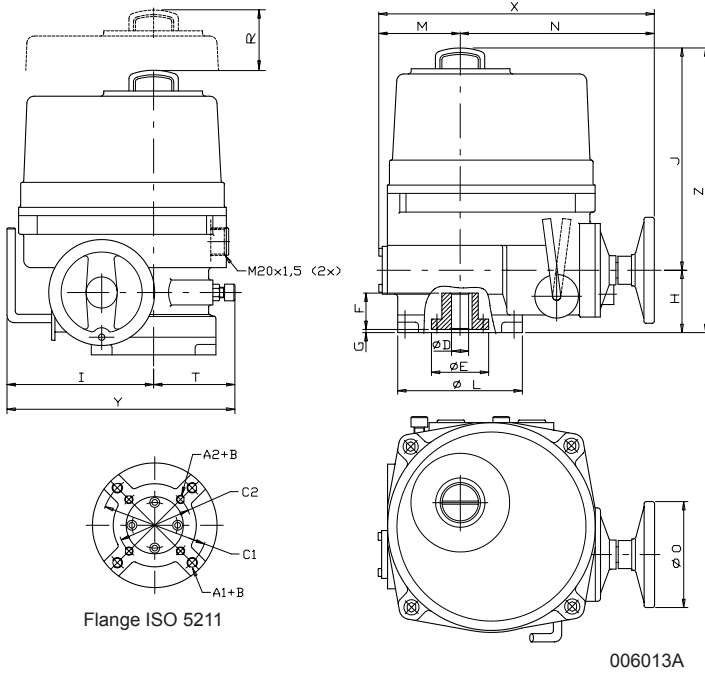

## RCEL150 - RCEL250

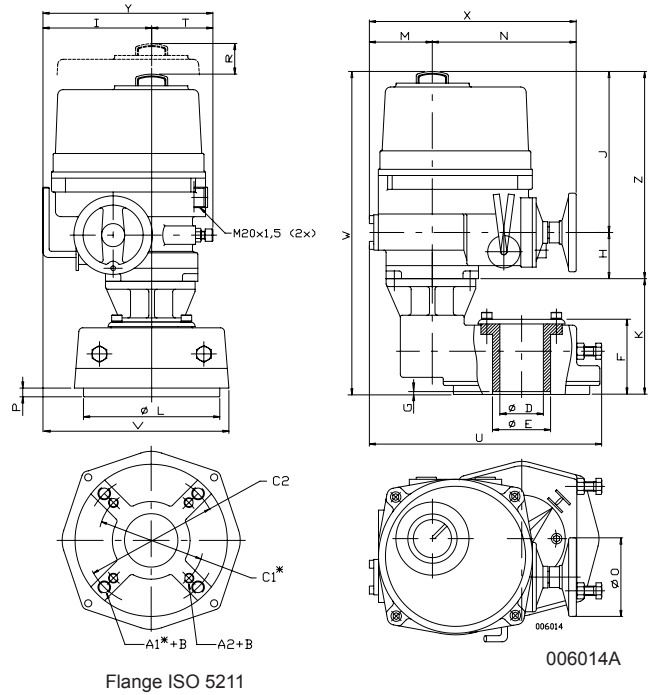

### RCEL006 - RCEL100

Type	RCEL 006	RCEL 009	RCEL 015	RCEL 019	RCEL 028	RCEL 038	RCEL 050	RCEL 060	RCEL 080	RCEL 100
Flange	F07	F07	F07/ F10	F07/ F10	F10/ F12	F10/ F12	F10/ F12	F12/ F14	F12/ F14	F12/ F14
C1	-	-	102	102	125	125	125	140	140	140
C2	70	70	70	70	102	102	102	125	125	125
A1	-	-	M10	M10	M12	M12	M12	M16	M16	M16
A2	M8	M8	M8	M8	M10	M10	M10	M12	M12	M12
B***	12	12	15	15	18	18	18	22	22	22
D (Max**)	22	22	22	22	32	32	32	42	42	42
E	55	55	57	57	75	75	75	85	85	85
F	43	43	43	43	52	52	52	59	59	59
G	2	2	2	2	2	2	2	2	2	2
H	60	60	60	60	70	70	70	78	78	78
I	113	113	139	139	159	159	159	191	191	191
J	213	213	213	213	250	250	250	283	283	283
L	102	102	120	120	145	145	145	175	175	175
M	56	56	77	77	83	83	83	99	99	99
N	175	175	184	184	202	202	202	226	226	226
O	102	102	102	102	125	125	125	170	170	170
R	108	108	108	108	130	130	130	178	178	178
T	68	68	85	85	99	99	99	116	116	116
X	231	231	261	261	285	285	285	325	325	325
Y	181	181	224	224	258	258	258	307	307	307
Z	273	273	273	273	320	320	320	361	361	361

\* = For optional alternative flanges  
 \*\* = Maximum dimension including keyway  
 \*\*\* = Thread depth

### RCEL150 - RCEL250

Type	RCEL 150	RCEL 200	RCEL 250
Flange	F16/F14*	F16/F14*	F16/F14*
C1	140*	140*	140*
C2	165	165	165
A1	M14*/M16*	M14*/M16*	M14*/M16*
A2	M20	M20	M20
B	30	30	30
D (Max**)	75	75	75
E	100	100	100
F	126	126	126
G	7	7	7
H	78	78	78
I	191	191	191
J	283	283	283
K	195	195	195
L	266	266	266
M	99	99	99
N	226	226	226
O	170	170	170
P	16	16	16
R	178	178	178
T	116	116	116
U	388	388	388
V	318	318	318
W	556	556	556
X	325	325	325
Y	307	307	307
Z	361	361	361



Remote Control Sweden AB  
 Box 80, Kontrollvägen 15  
 SE-791 22 Falun  
 Sweden  
 Tel +46 (0)23 587 00  
 Fax +46 (0)23 587 45  
 info@remotecontrol.se